



The Global Language of Business

An Introduction to the Serial Shipping Container Code (SSCC)

Release 3.0, February 2019



Table of Contents

1	What is a Serial Shipping Container Code?	4
2	What is an SSCC used for?	4
3	Key Attributes of the SSCC.....	4
4	Business Benefits of Using SSCCs	4
5	How is the SSCC formed?.....	5
6	Examples of an SSCC	6
7	Frequently Asked Questions About the SSCC	7
8	Tools and Resources	8

About GS1

GS1® is a neutral, not-for-profit, global organization that develops and maintains the most widely-used supply chain standards system in the world. GS1 Standards improve the efficiency, safety, and visibility of supply chains across multiple sectors. With local Member Organizations in over 110 countries, GS1 engages with communities of trading partners, industry organizations, governments, and technology providers to understand and respond to their business needs through the adoption and implementation of global standards. GS1 is driven by over a million user companies, which execute more than six billion transactions daily in 150 countries using GS1 Standards.

About GS1 US

GS1 US®, a member of GS1 global, is a not-for-profit information standards organization that facilitates industry collaboration to help improve supply chain visibility and efficiency through the use of GS1 Standards, the most widely-used supply chain standards system in the world. Nearly 300,000 businesses in 25 industries rely on GS1 US for trading-partner collaboration that optimizes their supply chains, drives cost performance and revenue growth while also enabling regulatory compliance. They achieve these benefits through solutions based on GS1 global unique numbering and identification systems, barcodes, Electronic Product Code-based RFID, data synchronization, and electronic information exchange. GS1 US also manages the United Nations Standard Products and Services Code® (UNSPSC®).

1 What is a Serial Shipping Container Code?

The Serial Shipping Container Code (SSCC) is the GS1 Identification Key used to identify a logistic unit. This unique identifier is comprised of an Extension Digit, a GS1 Company Prefix, a Serial Reference, and a Check Digit.

2 What is an SSCC used for?

The SSCC is used to identify an individual logistic unit. A logistic unit can be any combination of units put together for transport and/or storage where the specific unit load needs to be managed throughout the supply chain. Some examples of logistics units are cases, pallets, or air cargo containers. The SSCC enables a logistics unit to be tracked individually to support order and delivery tracking and automated goods receiving. Because the SSCC provides a unique number for the delivery, it can be used as a lookup number to provide not only detailed information regarding the contents of the load, but also as part of the Advance Ship Notice (ASN) process.

Typically, this means that just one scan of the SSCC on a logistic unit at a receiving bay can be linked to a pre-received electronic ASN of the contents of the logistic unit to facilitate speedy receiving, reconciliation, and put-away processes. Alternatively, when tracking a unit in transit, the SSCC provides all the information required for accurate identification. The SSCC can be captured when a specific logistic unit is dispatched, arrives at its destination, or at any other intermediary point in the supply chain.

If a logistic unit with an SSCC is travelling through a hub and is broken down and repacked, a new SSCC will need to be assigned to the new logistic unit. The SSCC can be used for any logistic units that require individual identification, such as couriered parcels, beer kegs, or even a whole container load. The SSCC is also useful for internal pallet or unit identification when the load is put away or moved within a warehouse or business.

The SSCC may be encoded in a GS1-128, GS1 DataMatrix, GS1 QR Code barcode and an Electronic Product Code (EPC®)-enabled Radio Frequency Identification (RFID) tag.



Important: The SSCC is fully compatible with ISO/IEC 15459—unique identifiers for transport units. This is often referred to as the ISO License Plate and is a prerequisite for tracking and tracing many international shipments.

3 Key Attributes of the SSCC

The SSCC can be used to uniquely identify any logistic unit enabling the logistics unit to be correctly identified anywhere in the world. Combined with GS1 Standards for electronic messaging, this "license plate" facilitates simple tracking of goods from the carton level all the way up to the trailer load level and beyond. In addition, the SSCC allows reliable lookup of complex load detail, which saves having to encode long detailed consignment information on individual logistic unit labels.

The serial reference component of the SSCC provides virtually unlimited number capacity, simplifying number allocation and guaranteeing unique identification. An SSCC can be assigned by a company anywhere in the world and can be used anywhere in the world.

4 Business Benefits of Using SSCCs

There are a number of benefits to using the SSCC for building a business-to-business tracking system, whether for finished goods or for raw materials. The structure of the SSCC and its assignment rules are

administered by GS1®, a not-for-profit standards organization, and is supported by implementation guidance, business examples, and maintenance. In addition, the SSCC:

- Uniquely identifies logistics units for tracking and identification
- Provides virtually unlimited numbering capacity
- Integrates with all GS1 supply chain processes
- Can be barcoded or encoded in EPC/RFID tags for simple scanning or reading
- Links barcoded or EPC/RFID tag information to electronic communications
- Enables fast lookup of transactional data
- Facilitates simple electronic messaging between companies
- Can be used at any stage in the supply chain for tracking
- May specifically identify a dispatch, a journey, or an arrival either within or between companies
- Applies to the entire supply chain, from raw materials supplier to manufacturer to distributor/wholesaler to end user/retailer
- Applies to both inter-company and intra-company transactions
- Encompasses a common vendor numbering scheme that uses the GS1 Company Prefix so that the number cannot be duplicated

5 How is the SSCC formed?

- **APPLICATION IDENTIFIER (AI):** AI (00) to indicate an SSCC
- **EXTENSION DIGIT:** Used to increase the capacity of the Serial Reference within the SSCC
- **GS1 COMPANY PREFIX:** A globally unique number issued to a GS1 member company
- **SERIAL REFERENCE:** The number allocated to identify a logistic unit
- **CHECK DIGIT:** A modulo 10 digit used to check for input errors

The Application Identifier (00) indicates that the GS1 Application Identifier data field contains an SSCC. When printed in a barcode the most common symbology is GS1-128. GS1 DataMatrix and GS1 QR Code are also allowed with restrictions. For details on the use of GS1 DataMatrix and GS1 QR Code, see section 2.2 of the [GS1 General Specifications](#). The SSCC may also be encoded using an EPC tag.

Figure 5-1 SSCC Structure

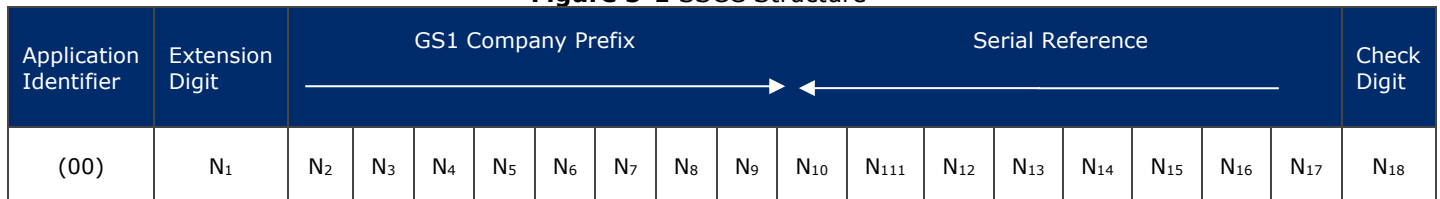

 **Note:** SSCC is an 18-digit numerical number, including the Check Digit. The combined length of the Extension Digit, GS1 Company Prefix, and Serial Reference will always total 17 digits.

The following steps are used to form SSCCs:

1. **USE THE EXTENSION DIGIT.** The Extension Digit is used to increase the capacity of the Serial Reference within the SSCC. It is assigned by the company that constructs the SSCC. The Extension Digit ranges from 0 to 9.

- 2. USE YOUR GS1 COMPANY PREFIX.** Your GS1 Company Prefix is the globally unique number issued to your company by GS1 US® or another GS1 Member Organization. GS1 Company Prefixes are assigned to companies in varying lengths. Some GS1 US members may have a prefix certificate that shows only a U.P.C. Company Prefix (formerly a UCC Company Prefix). A U.P.C. Company Prefix must be converted to a GS1 Company Prefix for use in the SSCC. This is accomplished by adding a zero to the front of the U.P.C. Company Prefix. The following table illustrates the conversion of a U.P.C. Company Prefix to a GS1 Company Prefix for use with SSCCs.

Figure 5-2 Conversion of a U.P.C. Company Prefix to a GS1 Company Prefix for GLN

U.P.C. Company Prefix	Converted to GS1 Company Prefix
801234	0801234
8412340	08412340
81123400	081123400

- 3. CREATE THE SERIAL REFERENCE.** This number is assigned by you, the holder of the GS1 Company Prefix, one-by-one to create a globally unique SSCC. The Serial Reference length varies as a function of the GS1 Company Prefix length.

- ✔ **Note:** The combined length of the Extension Digit, GS1 Company Prefix, and Serial Number is always 17 digits.
- ✔ **Hint:** Assign your Serial Reference sequentially, and do not build in any intelligence into the number. The scheme that defines a particular Serial Reference range as having a set meaning today will mean nothing a short time into the future in the event your company reorganizes, buys or merges with another firm, or when another staff member takes over SSCC assignment duties.

- 4. CALCULATE THE CHECK DIGIT.** The Check Digit is a calculated one-digit number used for data integrity. To understand how this digit is calculated, refer to www.gs1us.org/checkdig.

6 Examples of an SSCC

Figure 6-1 Examples of an SSCC in a GS1-128 barcode

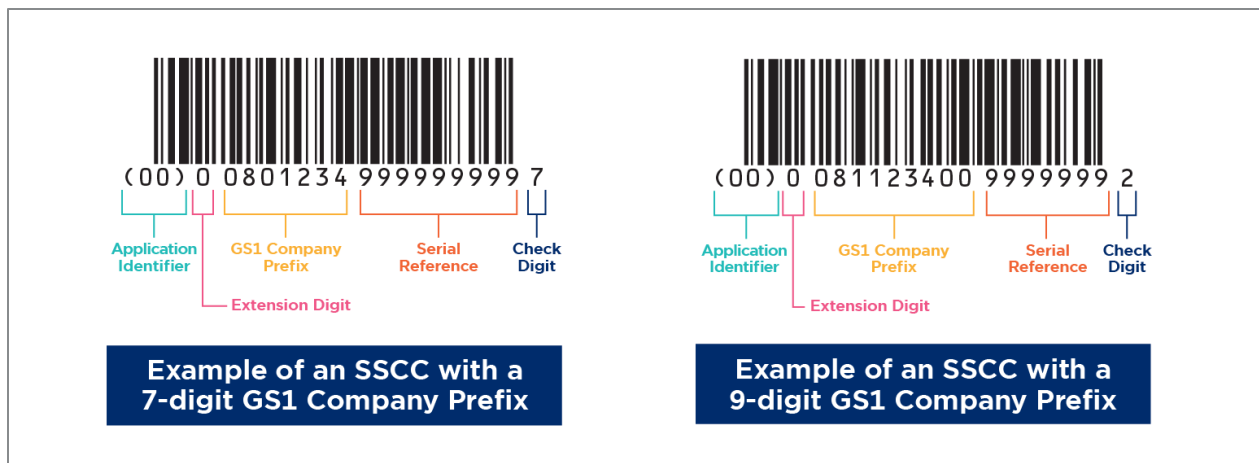
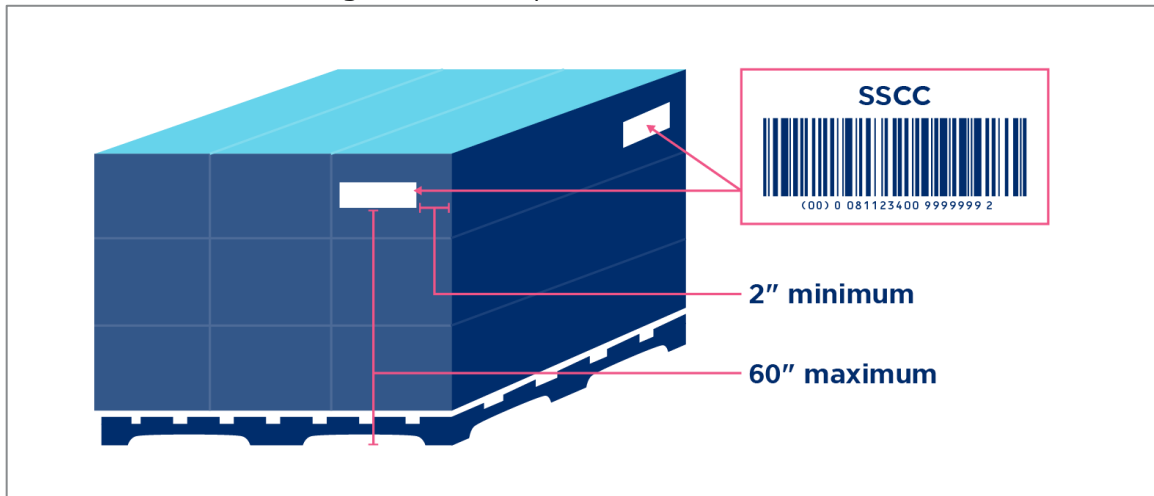

Figure 6-2 Example of an SSCC on a Pallet



Each pallet should have at least one barcode. It is recommended, however, that a pallet should contain an additional barcode on the adjacent side. This is especially helpful when the pallet is turned sideways in the truck or on the rack in the warehouse.

The SSCC should appear on the upper right half side of the pallet. Labels with barcodes should appear on the side of the pallet, 16-32 inches from the base of the pallet and at least 2 inches from vertical edge.

7 Frequently Asked Questions About the SSCC

Does my company need another GS1 Company Prefix to use SSCCs?

No. The GS1 Company Prefix that you already have been issued is used in the SSCC.

What are some examples of when I should apply an SSCC?

SSCCs are used to identify a logistics units, examples of which include a case, carton, pallet, or air cargo container.

Should the GTIN be included in the SSCC?

No. GTIN information is included in the Advance Ship Notice (ASN) that is sent to the receiver of the product prior to shipment. The SSCC acts as a license plate number. That number is linked to the ASN and provides access to the GTIN information.

How is an SSCC different than a GTIN?

SSCCs are distinctly different from GTINs. The SSCC acts as a license plate to track a shipment of logistics units through the supply chain. The GTIN uniquely identifies trade items (products and services).

Can the SSCC be used at the point of sale?

No. The SSCC is only used at the distribution or warehouse environment.

What is an Extension Digit?

The Extension Digit is used by the member company to increase the capacity of the Serial Reference. It has no defined logic and can be any digit between 0 and 9.

Do I need to purchase special equipment to scan an SSCC?

The equipment you choose should have software that is compatible with the type of scanner you have selected and should be able to read the GS1-128 symbol. If utilizing GS1 DataMatrix or GS1 QR Code, these symbols would need to be compatible and enabled with equipment as well.

How many SSCCs can I create?

With a 7-digit GS1 Company Prefix, one can assign 10 billion SSCCs (1-digit Extension Digit × 9-digit Serial Reference). With a 9-digit GS1 Company Prefix, one can assigned 100 million SSCCs (1-digit Extension Digit × 7-digit Serial Reference). That's a lot of shipments or logistics units that can be tracked!

Do I need to put more than one SSCC label on a carton or pallet?

Each logistics unit should have at least one barcode. It is recommended that a pallet should contain an additional barcode on the adjacent side.

8 Tools and Resources

GS1 US offers a number of easily accessible online tools and resources that can help guide you through the GS1 Standards and processes:

- [GS1 US Get Started Guide](#): Online guide to help you obtain a GS1 Company Prefix to create SSCCs.
- [Check Digit Calculator](#): Helps you ensure that the SSCC components have been entered correctly
- [Resource Library](#): Documents, videos, and other information to increase the value of standards for all trading partners in the value chain.
- [GS1 Logistics Label Guideline](#): Provides an overview of the normative rules and best practice recommendations based on GS1 Logistics Label implementations around the world.
- [FAQs](#): Frequently Asked Questions about GS1 Standards, implementation, and how to get started.

For more information about GS1 US, SSCCs, and other GS1 Standards:

- **Email** info@gs1us.org
- **Call** 937.435.3870
- **Visit** www.gs1us.org

Proprietary Statement

This document contains proprietary information of GS1 US. Such proprietary information may not be changed for use with any other parties for any other purpose without the expressed written permission of GS1 US.

Improvements

Improvement and changes are periodically made to publications by GS1 US. All material is subject to change without notice. Please refer to GS1 US website for the most current publication available.

Disclaimer

Except as may be otherwise indicated in specific documents within this publication, you are authorized to view documents within this publication, subject to the following:

1. You agree to retain all copyright and other proprietary notices on every copy you make.
2. Some documents may contain other proprietary notices and copyright information relating to that document. You agree that GS1 US has not conferred by implication, estoppels or otherwise any license or right under any patent, trademark or copyright (except as expressly provided above) of GS1 US or of any third party.

This publication is provided "as is" without warranty of any kind, either express or implied, including, but not limited to, the implied warranties of merchantability, fitness for a particular purpose, or non-infringement. Any GS1 US publication may include technical inaccuracies or typographical errors. GS1 US assumes no responsibility for and disclaims all liability for any errors or omissions in this publication or in other documents which are referred to within or linked to this publication. Some jurisdictions do not allow the exclusion of implied warranties, so the above exclusion may not apply to you.

Several products and company names mentioned herein may be trademarks and/or registered trademarks of their respective companies. GS1 US does not, by promulgating this document on behalf of the parties involved in the creation of this document, represent that any methods, products, and/or systems discussed or recommended in the document do not violate the intellectual property rights of any third party. GS1 US has not performed a search to determine what intellectual property may be infringed by an implementation of any strategies or suggestions included in this document. GS1 US hereby disclaims any liability for any party's infringement of intellectual property rights that arise as a result of any implementation of strategies or suggestions included in this document.

This publication may be distributed internationally and may contain references to GS1 US products, programs and services that have not been announced in your country. These references do not imply that GS1 US intends to announce such products, programs or services in your country.

No Liability for Consequential Damage

In no event shall GS1 US or anyone else involved in the creation, production, or delivery of the accompanying documentation be liable for any damages whatsoever (including, without limitation, damages for loss of business profits, business interruption, loss of business information, or other loss) arising out of the use of or the results of use of or inability to use such documentation, even if GS1 US has been advised of the possibility of such damages.

IAPMO

In this publication, the letters "U.P.C." are used solely as an abbreviation for the "Universal Product Code" which is a product identification system. They do not refer to the UPC, which is a federally registered certification mark of the International Association of Plumbing and Mechanical Officials (IAPMO) to certify compliance with a Uniform Plumbing Code as authorized by IAPMO.

GS1 US Corporate Headquarters

Princeton South Corporate Center, 300 Charles Ewing Boulevard
Ewing, NJ 08628 USA

T +1 609.620.0200 | **E** info@gs1us.org

www.gs1us.org

Connect With Us



6 1414102631 9